

Modeling different structures and verifying models from a system view with window regulators as examples

Zhao Xin, Sergey Petkun
xin.zhao.temp2@brose.com, sergey.petkun@brose.com
Brose Fahrzeugteile GmbH Hallstadt
Max-Brose-Straße 2 96052 Hallstadt Germany

Abstract

As the development of automobile industry, window regulator has evolved from manual window regulator to power window regulator with intelligent control. At present window regulator has turned into a complex mechatronic system. The electrical window regulator in a car is a classical example of mechatronic systems, because it contains all necessary components of mechatronic systems. With growing complexity from one hand and price pressure from the other, it is almost impossible to develop such system without good assistant tools. The system simulation helps to overcome the difficulties arising with requirements on market, such as shortening development time and decreasing its cost. In this paper it is shown how two different types of window regulators can be modeled using a uniformed way. A cross arm window regulator and rail guided cable driven window regulator are based on different working principles. And the great difficulty is to model both types in the same simulator platform. The both systems share the same functionality, although they are fundamentally based on different mechanical solutions. The ranges of working conditions of both systems are so wide that it leads to natural desire to replace numerous tests with modeling. The generalized approach for modeling such systems is discussed and the verification of models is introduced, which is to compare simulation result with simultaneous paralleled measurement from physical window regulator systems. A very important question is discussed how detailed models should be built.

1 Introduction

Since the appearance of the first vehicle, window regulator has evolved through states of manual window regulator at the first beginning, electrical power window regulator and electrical power window regulator with intelligent control nowadays. It turns from the simple mechanical component into complex mechatronic device, which involves not only mechanical structure any more but also electrical actuator, electronic hardware and software control for anti-pinch function [1]. With no doubt, window regulator has become mechatronic system. To develop such kind of mechatronic system, simulation turns out to be a good assistant method to face the challenge, because it saves time and cost for prototyping and increases efficiency and effectiveness to identify design failure in an early phase. Although simulation has lots of advantages over traditional techniques, it is not omnipotent. How well simulation could help in practical system development is still

related to many factors. Basically, the system to be modeled comes to the first place and in this paper it is window regulator.

At present, cross arm window regulator and rail guided cable driven window regulator are the two structures of window regulator which are widely used in vehicle doors. As seen in figure 1 and figure 2, the structures of cross arm window regulator and double rail guided cable driven window regulator (double rail window regulator) are quite different. Besides, the two structures share no common in aspects of working principle, kinematic and dynamic properties. The principle of cross arm window regulator is like a lever. It transforms and magnifies a rotational movement from electrical drive into a translational movement in glass moving direction. However, in double rail window regulator, electrical drive pulls cable, around cable drum, to lift up and pull down window glass through glass carriers. Such structure provides a constant glass speed, while cross arm window regulator does not. And cross arm window regulator has a poorer acoustic performance, compared with rail window regulator. Even cross arm window regulator is heavier than rail window regulator. However, cross arm window regulator is not of no features. Its advantages over rail window regulator lie on the convenience of its install in vehicle door and the competitive price. So on and so on. There are even more aspects to compare and to show that the two widely-used structures of window regulators are different.

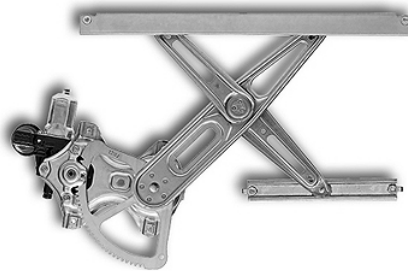

Figure 1: Cross arm window regulator

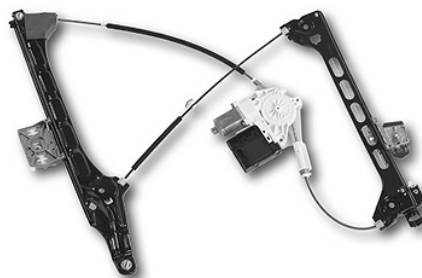

Figure 2: Double rail guided cable driven window regulator

For many reasons, among which cost is the first one, simulation is used as an aided tool in the development of systems like window regulator. Another reason to utilize simulation is the increasing complexity of systems. And the third one is the great range of customer requirement hidden in the specification of functionality under all circumstances.

For these reasons, simulation is used in development of window regulators. Traditionally, it is easy to come up with the idea that the two window regulators could be modeled in a separated way. In the case of cross arm window regulator, the driving arm of cross arm window regulator is made of metal and it bends slightly in the direction of glass movement. If the bend of arms is neglected, the mechanism could be taken as rigid body and modeled as ideal levers [2]. In certain simulation environments like MSC Adams or SIMPACK, the model is easy to build on the basis of multi-body dynamic system. In a more complex way, when bend is taken into account, the strain and the stress of arms could be modeled as flexible body in FEM. For rail window regulator, there has not been a satisfactory way to model flexible cable, as its shape is changeful in space. But it is possible to model the part of cable in rail window regulator with finite strain model [3]. Nevertheless, such method is too complicated to be implemented for the practical use. It is possible to implement artificial solution for flexible elements such as cable, but it is too expensive and the calculation duration increases dramatically. This approach requires also CAD data, which excludes the possibility of analysis at acquisition phase of projects when CAD data does not exist yet. From the other aspect, for system analyses, such method has no practical sense. In another method, cable is assumed as a spring with high stiffness [4].

Theoretically, it works to model the two types of window regulator separately by two methods. The disadvantage of such approach is that models of the two window regulator are irreplaceable. Practically it costs time and money to develop two set of simulation systems based on different simulation strategies. In reality, the requirements from the industry are [5]:

- Lower development time
- Lower cost
- Faster response of design and functionality failure at early phases of projects

Correspondingly, the goals of simulation [6] as an approach to develop mechatronic system in automobile industry, with window regulators here as examples, are:

- The simulation system should be capable to simulate the both constructions of window regulators
- The models of components should be substitutable
- Shorten the time to develop new models of window regulators for new projects

In this paper, a practice is presented, which avoids the disadvantage mentioned before, to model the two different structures of window regulator separated with two modeling methods. The practice witnesses the ability of simulation to meet the raised requirement of lower development cost and time in the fast developing automobile industry. In this case, modeling is brought from the level of individual parts up to the level of systems, which helps to understand what is necessary to model detailed in individual parts.

2 Modeling different structures from system view

The first question which has to be answered in this section is why the two structures of window regulators can be modeled within the same simulation system. The answer to such question is that modeling is carried out from a system view.

Window regulator is seen as a system, which means it consists of components with different functions and they interconnect with each other to build up complete system. In window regulator, the system consists of electrical drive, mechanical parts, electronic hardware and software. Electrical drive, electronic hardware and software, the standard parts, are used in both cross arm window regulator and rail window regulator. Each of the standard constituent components has the same functions and has the same ports to interconnect to each other. And the connection between these common parts and mechanical parts is uniformed to be identical for different window regulator systems. In this way, the two window regulators can be modeled.

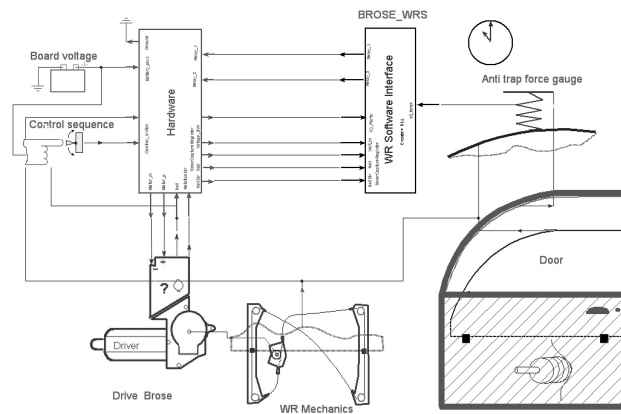

Figure 3: Diagram of Rail window regulator in simulation [7]

As shown in figure 3 and figure 4, the uniformed connection points enable the two window regulators to be simulated in the same simulation system. The ports of mechanical parts are one port to connect to electrical drive and the other to glass position as output. It is the same for cross arm window regulator and rail window regulator.

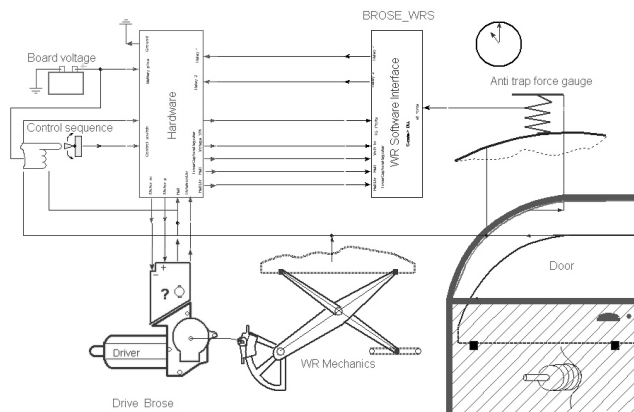

Figure 4: Diagram of cross arm window regulator in simulation [7]

From another point of view, the function of window regulator mechanism in door system is to lift up and pull down window glass. The electrical power is transferred into mechanical components by means of electrical drive. And it goes into window glass movement and also to overcome the friction between glass and door seal. It is the general function of window regulators and from this sense cross arm window regulator and rail window regulator have no difference. In a deeper level, window regulator could be taken as a black box to process the movement from electrical drive. The function of window regulator is just to transform the rotational movement from electrical drive into the translational movement of window glass. Additionally, every mechanical system has loss in form of friction, so it is with window regulators. It is just different how high the mechanical efficiencies of the two structures are. In summary, the main functionalities of cross arm window regulator and rail window regulator are the same, to lift up and pull down window glass. The same functionality makes it possible to model them in the same manner from a system view.

As mentioned above, window regulator system consists of electrical drive, mechanical part, electronic hardware and software. Electrical drive, electronic hardware and software are applicable to both cross arm and rail window regulator. Mechanical parts, which define window regulator system, classify window regulators based on different working principles. However, they have the common functionality, that is, to transfer force from electrical drive to window glass. Cross arm window regulator lifts window glass by lever-like arm, while rail window regulator does it by cable. How the two working principles are modeled is explained as in figure 5 and 6. In the case of rail window regulator, here with single rail window regulator as example, its model forms a closed loop, because all the components in rail mechanism are connected through by cable. Electrical drive drives cable drum, on which cable is held in great tension around. And cable goes through bowden, which is used to confine the path of cable. The contact between surface of cable and bowden brings friction loss into system. Going out of bowden, cable goes around pulley. The contact between the two components brings friction too. Then cable is connected to glass carrier and from there cable goes around the other pulley, through the other bowden and then back to cable drum. Between one end of bowden and cable drum housing, compensation spring is implemented to prevent hard sudden contact. The tension in cable is also indicated by the deformation of compensation spring. As the analysis above, the components of bowden and pulley bring only friction into the system, which is indicated as $F()$, force change, in figure 5. Compensation spring brings no loss of friction but only change of position, indicated by $P()$, as it has deformation. The rest of components, cable drum and glass carrier, brings not only friction but also change of position into the system. As cable is under great tension even when window regulator is at ease, the variation of cable deformation during window moving is so insignificant that the deformation of cable is neglected and cable is taken as a rigid body. In this way, all components of rail window regulator are interconnected to each other as in figure 5. From kinetic view, the rotational movement from electrical drive is transformed into translational movement at cable drum. The translational movement is changed after it goes through compensation spring, while through bowden and pulley the movement is

unchanged, because the cable deformation through these parts is negligible. At glass carrier, the translational movement is transferred to window glass, which finishes the kinetic process. From dynamic view, the torque of drive is transformed into force, which overcomes the resultant force of friction from bowden and pulley, glass weight and friction from door sealing. However, in the case of cross arm window regulator, the model presents open loop. Rotational movement is transformed and processed by pinion segment, driving arm and supporting arm. The later two parts transfer movement to window glass. Dynamically, pinion segment, driving arm, supporting arm, supporting rail all brings friction into system. The torque from electrical drive has to bear friction from them and load from glass.

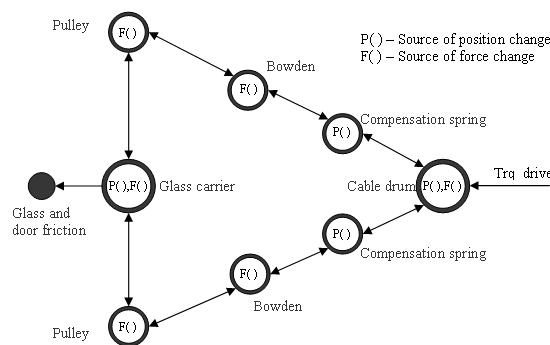

Figure 5: Diagram of single rail window regulator

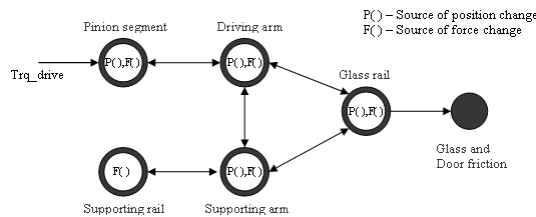

Figure 6: Diagram of cross arm window regulator

As seen in figure 5 and 6, although the working principles of cross arm window regulator and rail window regulator are different, it is the same that the two types of window regulators transform movement from rotational one into translational one. So, the functionality of the two types of window regulators is the same. Based on the analyses above, models of the two types of window regulators are built up in MAST modeling language, which is designed for Saber simulator from company Synopsys. MAST is not the only modeling language for implementation in this paper. Other modeling languages, like VHDL-AMS and Modelica, are also suitable.

The next interesting question is how detailed parts should be modeled. It is about the depth of modeling. In another way to say, the question is whether it is necessary to model all the effects happening in parts. Simulation is powerful, but it is only in certain degree. Simulation casts light only on one perspective of subjects but not all perspective, which is

its limit. So, before simulation models are built, it is very necessary to set the questions which are supposed to be answered during simulation. It brings basic criteria to the question how detailed parts should be modeled. Here three suggestions are proposed for degree of subject modeling,

- The models should be at least able to answer the questions, which are supposed to be answered in simulations.
- All parts constituting system should be appropriate to each other. In another words, the models of parts should not be poorer than the least detailed parts in systems.
- The physical phenomenon or properties, which have relevantly very low impact on the simulation result compared with physical measurement, could be neglected from modeling.

3 Verification of models

A model without verification is not practically useful, especially in the case of window regulator, which is highly related to reality. In this section, how to verify simulation models, paralleled to physical system, is presented. It exams how close the simulation models are to the real mechatronic system.

The origin of the verification method is that window regulator is under controlling and monitoring of electronics all the time. The controlling signal to window regulator comes from electronics, which is in fact instruction or operation from human. And the feedback is rotational velocity information measured at electrical drive armature. Motor current is also possible as feedback. The rotational velocity information is sent back to electronics and electronics determines what to do and how to do in case of pinches. For window regulator electronics, only velocity information is in focus and all other states about systems are calculated based on it. However, it does not matter whether the window regulator is real or not, only if it could provides electronics the correct velocity information. So, as shown in figure 7, a control signal, which could be real control switch signal or virtual one, is given to window regulators. Window regulator model and real window regulator begin to move, no matter whether to move up or down. The speed information at electrical drive armature is measured in both physical system and simulation model and then sent to electronics, which could be implemented in real electronic hardware or virtually in computer environment. Electronics now could make calculation and then comparison between real window regulator and its model can be made paralleled.

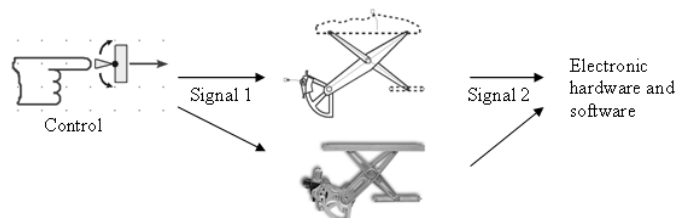

Figure 7: Method to verify models

In verification, simulation models are compared with real systems. In comparison, three components of window regulator are examined, that is, electrical drive, mechanism and door model. In fact, it is the synthetic performance of the three physical components that is compared with parts in real systems. However, before such verification is conducted with the integrated system, individual part should have been verified with corresponding part in reality. Only with reliable verification, the synthetic comparison between the whole window regulator models and real window regulators is of meaning. In contrary, it is not necessary to verify the rest parts of system. The reason for it is that manual switch, electronic hardware and software can all be virtually released within computer as identically as in reality. The advantage of it is that various hardware and software implementations could be tested on the same mechanism to find out the best solution for commercial projects.

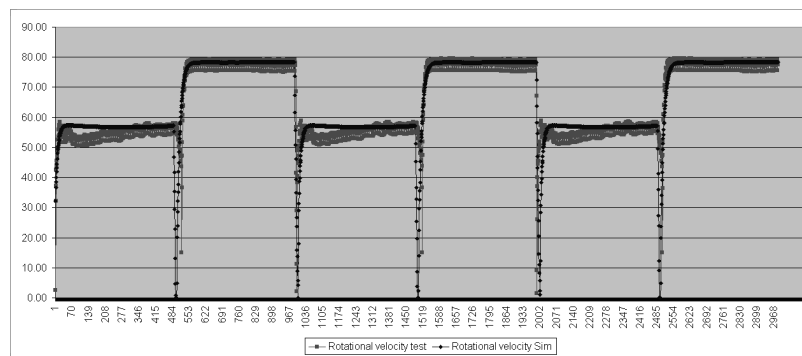

Figure 8: comparison between simulation result and practical measurement

In figure 8, it is an example of verification, which compares the anti-pinch function of cross arm window regulator. The two signals in figure are the rotational velocity of electrical drive armature from both simulation and real window regulator. The movement of window regulators is under the control of manual switch. The manual control signal is to lift up window glass automatically from a lower position until it hits obstacle. Then anti-pinch function enables glass reversing. Again, control signal lifts up glass for another pinch event. During glass goes up, the electrical drive speed is lower because the load is the sum of glass weight and friction. While glass reverses, electrical drive speed is higher because gravity of window glass is working as an active factor. In the figure, the darker signal is simulation result of motor speed, while the lighter one is the real measurement from real window regulator. It is seen that the two signals fit to each other approximately. Motor speeds during lifting up and reversing are at the same level, while they fit better during glass going down. However, a difference happens at the start-up of lifting process. Motor speed of simulation has a smooth process to reach the stable value, while real system experiences a process of vibration before it reaches stable. From one aspect, the simulation models perform well to represent anti-pinch process of window regulator. With the same position of obstacle, anti-pinch function of simulation models is activated as the same time as real window regulator. Under such context, the models are acceptable. However, from another aspect, it may not be acceptable because of the inaccurate imitation of motor speed at starting up. It comes back to the question how

detailed models should be built or how close models should be to the real subjects. One thing is true that people can not expect simulation to answer once for all every question we are interested in. If simulation could answer the questions which are designed to be answered by simulations, the simulation is acceptable. If people would like to know more or further questions are raised during simulation, improved models have to be built and more effects of subjects should be taken into account. It is all based on expectation of simulation.

4 Conclusion

In this paper, a practice is presented, in which two different structures of electrical power window regulator with intelligent control were modeled. The method behind the practice could save the effort to build up two separated simulation system for window regulators based on two working principle. Meanwhile, it could also give possibilities to compare some different mechanical systems based on various principles and investigate their advantages and disadvantages. By utilizing uniformed interconnecting ports, standardized parts, like electrical drive, electronic hardware and software, can connect to mechanisms, which are based on different working principles, that is, cross arm mechanism and rail guided cable driven mechanism in this paper. The common functionality of the two structures of window regulators makes the uniformed interconnection possible.

Moreover, corresponding to modeling, verification of models is introduced. With the verification, simulation models can be compared to real window regulator system at the same time, which increases the effectiveness of models evaluation and improves the reliability afterwards. It saves also the effort to build up models for manual switch, electronic hardware and software. They can all be digitalized in computer with less cost. Then certain physical models, that is, electrical drive, window regulator mechanism and door, are examined precisely.

At last, the criteria of the suitability of simulation models for designed purposes change all the time as the development of models. The question, whether models are suitable or not, depends on factors, like the subjects to be modeled itself, the understanding about the being modeled subjects, the selection of modeling language and the powerfulness of computer hardware, so on. If the simulation models could satisfy the need of simulation assignments, it is acceptable. And if more information is required from simulation models, improvement and more physical effects have to be taken into account in building models. For this reason, several suggestions regarding the modeling level are proposed in the paper.

5 Literatur

- [1] *Schooler P.T.*: Anti-pinch power window system, United States Patent 7021001

- [2] *Liao H.B., Liu D.B., Guo X.H., He Q., Hou S.Y., Jin Y.Y.*: Superficial Analysis of Electric Window regulator. *Machine Design and Research*, 2007
- [3] *Perkins, N.C. Mote C.D.*: Three-dimensional vibration of travelling elastic cables. *Journal of Sound and Vibration*, Volume 114, Issue 2.
- [4] *Petkun S., Khader S.*: Dynamische Modellierung eines Antriebes mit Zugmittelgetrieben. *Robotik und Automatisierungstechnik*, 47. Internationales Wissenschaftliches Kolloquium, TU Ilmenau, 23.-26. September 2002
- [5] *Murmann, P.A.*: Expected development time reductions in the German mechanical engineering industry.
- [6] *Karnopp Dean C.*: *System Dynamics: Modeling & Simulation of Mechatronic System*, (4th Ed.), 01-2006
- [7] *Petkun S.*: Modeling of mechatronical devices with Saber, SNUG Europe 2008